

## SERVICING

- It is recommended that Nefa Tempering Valves are checked annually by a qualified plumber in accordance with AS4032.3.
- Where the water supply is of poor quality or any other supply variations are likely, it may be necessary to check the Tempering Valve at more frequent intervals.
- This valve is a safety valve and cannot be serviced. If the valve fails to operate it is to be replaced.
- No attempt should be made to dismantle the valve. Any attempt to dismantle the valve (other than adjustment cap) will void all warranties.

## TROUBLESHOOTING

What is wrong!	Causes	How to fix it
No flow from valve	No or low water supply at inlets	Check inlet pressures and flows Restore inlet supply pressure
Fluctuating or low flow rate	Fluctuating or incorrect supply pressures	Ensure inlet supply pressures are balanced May require Pressure Limiting Valves on inlets
Outlet temperature unstable or varying over time	Fluctuating or low temperature hot water supply Fluctuating or incorrect supply pressures Fluctuating or low temperature hot water supply	Check and adjust hot water supply temperature and pressure
Outlet temperature cannot be adjusted	Valve installed with inlets reversed	Install valve as shown in instructions and re-adjust outlet temperature
Noise	High water velocity	Reduce water velocity Limit inlet pressure

### Warranty Statment

Where Methven tapware or valving (tapware) is purchased for use or on-sale in the context of any business, Methven undertakes to either repair or replace (at its option) that tapware if it is discovered that such tapware contains a material defect, which arose in the course of manufacture.

This undertaking shall not apply if:

- The defect is brought to Methven's attention later than 2 years after the date of purchase, where the defect relates to washers, "O" rings, lip and other seals and powder coating, or 5 years where the defect relates to any other tapware componentry. All single lever ceramic disc cartridges specified for mains pressure only use, has a lifetime warranty.
- There is a failure by any person to follow Methven's installation instructions or the tapware is used other than in accordance with Methven's specifications.
- Evidence cannot be produced which confirms that the relevant tapware was purchased from a Methven authorised distributor.
- Repair work is performed on the relevant tapware by a person other than Methven, its authorised service agents or any plumber who has not received authorisation prior to proceeding with the work.

Conditions:

Proof of purchase details (such as invoice or receipt) will be required to claim under this warranty. Lifetime warranties are applicable, where mains pressure use only has been specified, on ceramic disc cartridges and will result in replacement of defective parts.

The above undertaking from Methven shall also apply to any purchaser of Methven tapware who is a "Consumer" under the Consumer Guarantees Act 1993, in addition to any other right or remedy which such person may have under that Act.

Methven shall in no way be liable to the purchaser or user of any tapware, for any loss, damage (direct, indirect or consequential), cost or expense suffered or incurred by that person, otherwise than as provided in the above provisions, or as provided under the Consumer Guarantees Act 1993.



Designed, distributed and warranted by Methven Limited,  
Private Bag 19996, Avondale, Auckland, NZ.  
447 Rosebank Road, Avondale, Auckland

## MAINS PRESSURE

## TEMPERING VALVES

Trust NEFA to safely deliver heated water.

**NMTV:** for electric, and gas storage heaters.

**NSTV20:** for solar and demanding applications where supply conditions may fluctuate.

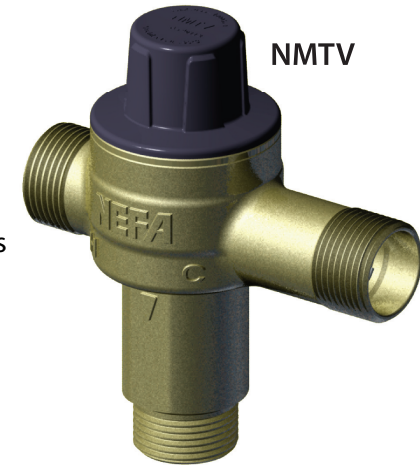

- Accurate temperature control means safe controlled temperature hot water delivered to sanitary outlets.

- Fail Safe: Failure of cold water supply causes valve to close and shut off hot flow.

- Dezincification Resistant (DR) Brass.

- Advanced polymers for greater resistance to calcium deposits and reliable service.

- Integral non-return valves.

- Tamper-proof adjustment; with special Adjusting Tool supplied.

- NEFA Tempering Valves comply with the requirements of NZBC G12.

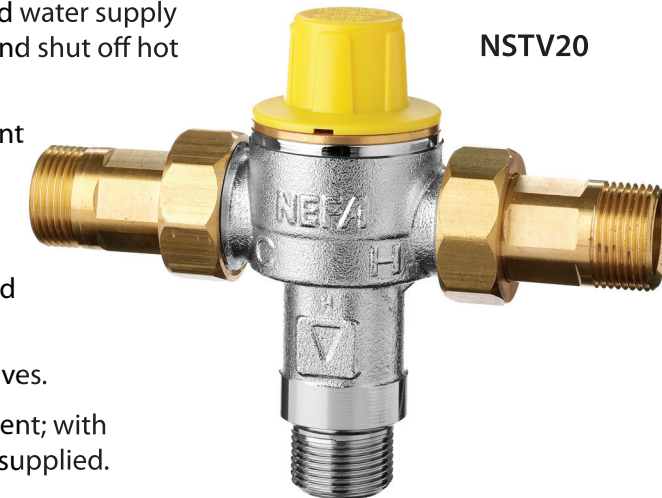

**NEFA** LEADING WATER VALVE TECHNOLOGY

## SPECIFICATIONS

- Connections: 20mm (¾" BSP) Male
- Recommended Outlet Temperature range: 40° C - 55° C<sup>2</sup>
- Factory setting: 55° C nominal (Must be commissioned on site)
- Accuracy of mixed outlet temperature: ±3° - Tested to AS 4032.2
- Cold water supply: 5° C - 25° C
- Hot water supply: NMTV: (Gas & Electric Storage) 60° C - 90° C<sup>1</sup>
- NSTV20: (Solar Installations) 60° C - 99° C<sup>1</sup>
- Hot water / mixed water temperature differential: 15° C minimum.
- Supply Pressure - Static: 1600 kPa maximum
- Supply Pressure - Dynamic: 500 kPa maximum
- Maximum permitted pressure variation at inlets: ±10% maximum<sup>4,5</sup>
- Pressure supply differential - Dynamic: 3:1 maximum<sup>3</sup> (At time of commissioning)
- Minimum flow rate: 4 Litres/min

**For solar installations and applications where fluctuating supply pressures may occur such as instantaneous water heaters NEFA recommend the installation of an NSTV20 High Performance Solar Tempering Valve.**

### Notes:

1. The Building Code Approved Document G12 clause 6.14 states that water shall be stored at not less than 60° C to inhibit the growth of legionella bacteria. To obtain good tempering valve response the cylinder thermostat should be set at a minimum of 65° C.
2. The valve can be set as low as 35° C or as high as 58° C, depending on site conditions. The temperatures are outside the optimum working range of the valve and the requirements of G12.
3. The maximum ratio permitted between supply pressures, under dynamic flow operation. It is recommended at time of commissioning that hot and cold pressures be as equal as possible.
4. The maximum permitted pressure variation in either supply from commissioning pressures in order to maintain the outlet temperature to ±3° C.
5. Note: Steps should be taken to eliminate any causes of rapid changes in supply pressures, as this may result in an outlet temperature spike greater than ±3° C from commissioned temperature. If a spike occurs it may take a few seconds for the temperature to stabilise back to within ±3° C.

## OPERATION

- NEFA Tempering Valves are designed to accurately provide safe controlled temperature water for outlets primarily used for personal hygiene. They will maintain the outlet mixed temperature to ±3° C from set temperature.
- NEFA Tempering Valves will effectively mix to 55° C when supplied with 60° C hot water.
- If the cold water supply to the valve fails then the valve will automatically shut off the hot water supply preventing scalding. 15° C differential between the hot inlet water temperature and outlet set temperature is required to ensure effective hot water shut off.
- Optimum performance of the valve is obtained when the hot and cold dynamic (flowing) supply pressures are equal. Static supply pressures (non-flowing) will not give a true indication of dynamic pressures.
- In a domestic installation it is recommended that a NEFA pressure limiting valve is used at the property boundary to limit pressure to the whole site.
- Where inlet pressures may be unbalanced, as in commercial installations with separate hot and cold water supply, it is recommended that separate NEFA pressure limiting valves be fitted to both inlets of the Tempering Valve for optimum performance and that check valves be fitted the hot and cold water supply.
- Not to be used on steam supplied systems.
- Not to be used on low pressure systems.

## INSTALLATION

- NEFA valves should always be installed by a qualified plumber in accordance with the NEFA installation instructions. The installation must also conform to the requirements of the Building Code and the Department of Building and Housing's approved document G12 Water Supplies and must also comply with Local Authority requirements.
- A separate un-tempered hot water line to the kitchen and laundry is recommended.
- Do not install directly onto a hot water cylinder. It is recommended that the valve be installed as close to the hot water source as possible. For optimum performance install with a 150mm thermosyphon between the cylinder outlet and hot inlet. (Ref Figure 1).
- If installed at an outlet fixture, 1m of pipe must be installed between the tempering valve and the outlet.
- Strainers are essential to prevent debris entering the tempering valve that could prevent it working effectively. All installations should have line strainers fitted. It is recommended that a NEFA NPC500 pressure limiting valve (with integral filter/strainer) is installed upstream of the cold inlet.
- Always flush pipes before connecting valves.
- The use of excessive thread sealant (liquid, tape or any other form) must be avoided as this may cause the valve to fail.
- Never expose valves to a torch flame or heat. Heat will destroy the seals and sealing parts.
- Never expose valves to freezing conditions. If installed where freezing conditions may occur, then suitable insulation must be used to prevent damage to the valve.

*Once installed, EVERY valve must be commissioned. Measure the hot water temperature at the outlet closest to the NMTV. A thermometer must be used. Adjust the set temperature of the tempering valve to deliver the correct water temperature. 45° C for early childhood centres, schools, rest homes, institutions for people with psychiatric or physical disabilities, hospitals, and 55° C for all other buildings.*

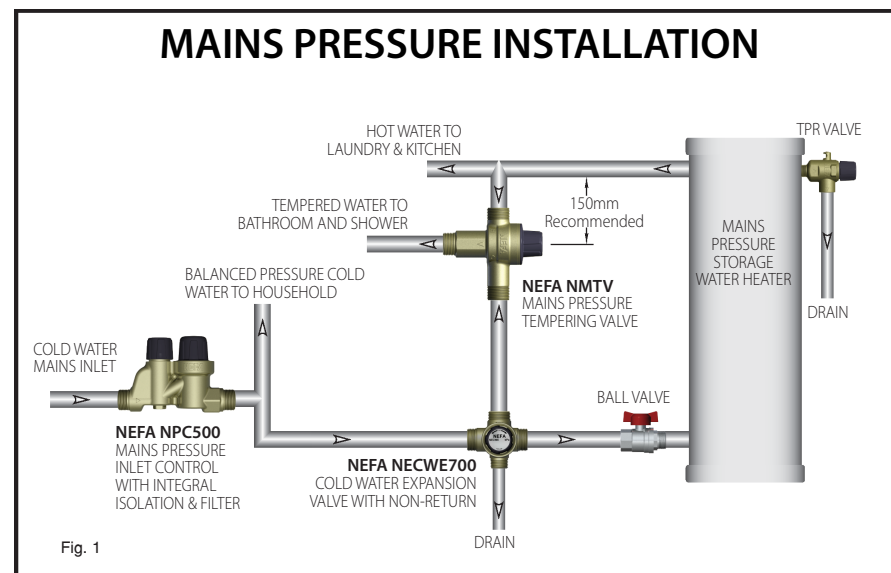

## VALVE ADJUSTMENT

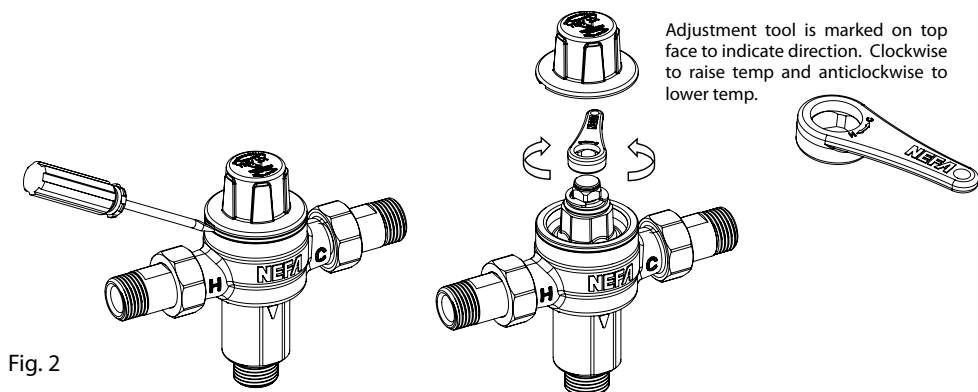

Fig. 2

- Before setting the valve, ensure the hot water source is switched on and supplying water within the specified hot water temperature limits. It is recommended the water heater, if controlled by an adjustable thermostat should be set to the required 15° C differential temperature necessary for thermal shut off.
- Allow the water to flow 1-2 minutes to ensure the mixed water temperature has stabilised.
- A thermometer must be used to test the hot water at the nearest outlet to the installed valve to ensure the correct mixed water temperature is supplied. Test at a flow rate of not less than 4 litres/minute.
- Using the adjusting tool supplied, simply rotate the spindle shown in the direction (H) hot or (C) cold as indicated on the tool until the required set temperature is achieved.
- Once the set temperature has been reached and tested with a thermometer the cap must be snapped back onto the valve to protect the spindle from accidental adjustment.

## DIMENSIONS

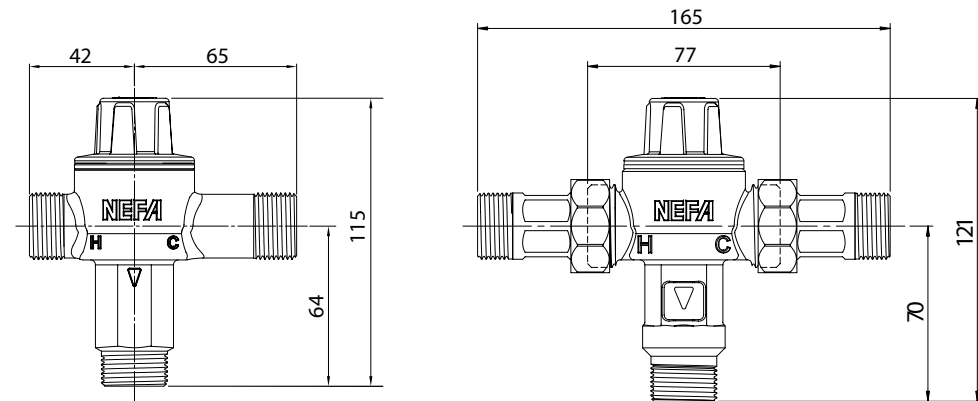

Fig. 3 NMTV

Fig. 4 NSTV20